



Büro für Tragwerksplanung und Ingenieurbau
vom Felde + Keppler GmbH & Co. KG

Lütticher Straße 10-12
52064 Aachen
www.vom-felde.de

Telefon: 0241 / 70 96 96
Telefax: 0241 / 70 96 46
buero@vom-felde.de

Preliminary Structural Report

Prerig Truss

18228-AUS

Date 15/01/2020

for the system by

Global Truss
Furong Industrial Area
Shajing Town

Baoan District Shenzhen China

Compiled by:

Aachen, 15.01.2020



This Structural Pre-Report includes pages

1 - 24 + annex

This Structural Pre-Report is set up exclusively for the company Global Truss.
Forwarding to third parties only with the author's approval.



TABLE OF CONTENTS

1 PRELIMINARY NOTES	1
1.1 Basics	1
1.2 Materials	1
1.3 General remarks	1
1.4 Geometry and loadings	2
2 SYSTEM.....	4
3 SECTION- AND MATERIAL PROPERTIES	5
4 ALLOWABLE LOADING SINGLE COMPONENTS	8
5 ALLOWABLE LOADING SINGLE SPAN GIRDER	16
5.1 Center chords at top	16
5.2 Outer chords + bracing uniformly distributed load (UDL).....	22
6 SUMMARY OF RESULTS	23
6.1 Allowable loadings:.....	23
6.2 Deflections at max. allowable loadings:	24
annex	
drawings of trusses	
	L = 3050 mm
	L = 2440 mm
	L = 1220 mm
	male fitting
	female fitting



1 PRELIMINARY NOTES

1.1 Basics

The currently applicable regulations and standards, in particular:

DIN EN 1991-1	Actions on structures (Eurocode 1)
DIN EN 13814	Fairground and amusement park machinery and structures
DIN EN 13782	Temporary Structures – Tents
DIN EN 1993-1	Design of steel structures
DIN EN 1999-1	Design of aluminium structures

1.2 Materials

Tubes	Aluminium EN AW-6082 T6
Bolts	Grade min. 10.9
Pins	Steel S45C (C45)
Fittings	Aluminium EN AW-6061 T6

1.3 General remarks

The truss system is part of a "modular construction system". In this preliminary report the following truss lengths are regarded: 3050 m, 2440 mm and 1220 mm.

The Trusses consist of 3 upper and 2 lower main chords (round tube 50 x 4mm), which are arranged in a rectangular shape. The center chord at the top is connected to the outer chords by cross tubes (round tube 50 x 4mm). The trusses also consist of welded diagonal bracings (round tube 25 x 3mm). The truss is stiffened by bracings at both vertical sides.

The distance between system lines of the mainchords is 30,5 cm in vertical- and 54 cm in horizontal direction.

The trusses are connected at the 4 outer mainchords with couplers consisting of male and female fittings, connectors and bolts. Each insterted fitting is connected with 2 pins to the chord. The center chord of the top is not connected with couplers.

The loads are applied at the center chord of the top. The allowable loads are listed in tables (see chapter 6).

The verification of the single parts is done according the safety concept of EN 1990 with a partial safety factor of the loading side of 1.50 for payloads.

For applications which can be calculated on the basis of other codes, the partial safety factors can be adjusted (for example temporary structures acc. EN 13814, $\gamma_F = 1.35$ for payloads).

To use the resulting allowable loads with British Standard (BS) and ANSI, the allowable loads listed in tables have to be multiplied by 0.85.



1.4 Geometry and loadings

The load can be applied as a distributed load or as multiple point loads on the central top chord.

The allowable loading on the prerig truss is limited by two conditions:

- 1) First condition is the local load transfer from the central top chord to the bracing node.
- 2) Second condition is the global load transfer to the truss supports.

Resulting allowable loading, see chapter 6

The following principle loadcases and loading situations are taken into account:

Structural system:

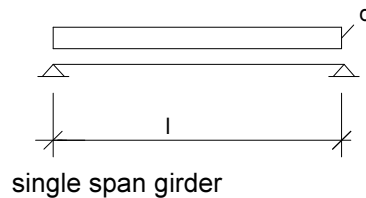

Loading situation

- a) uniformly distributed load (UDL) on central top chord

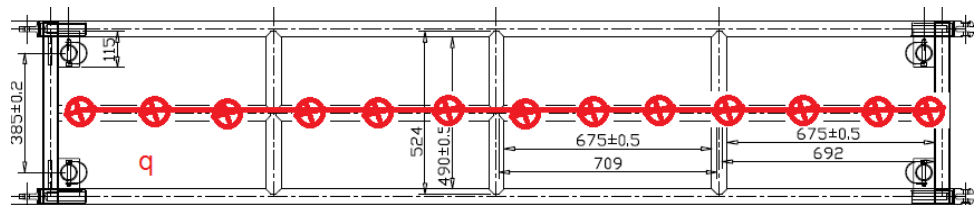

- b) multiple point load on central top chord with maximum point load of $P_i \leq 200 \text{ kg}$ and distances $\geq 50 \text{ cm}$ (equivalent to a distributed load of $\leq 400 \text{ kg/m}$). No restrictions concerning position on the central top chord but allowable loading in dependence of the span has to be respected, see chapter 6.

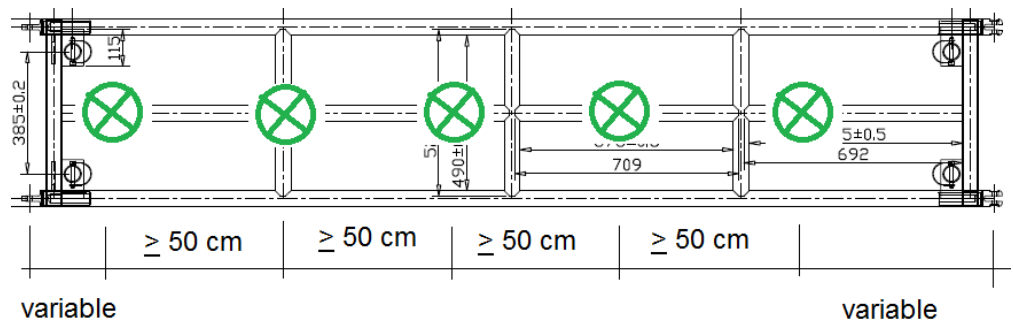

The selfweight of the truss is approx. 16 kg/m



For the support or suspension there are the following possibilities:

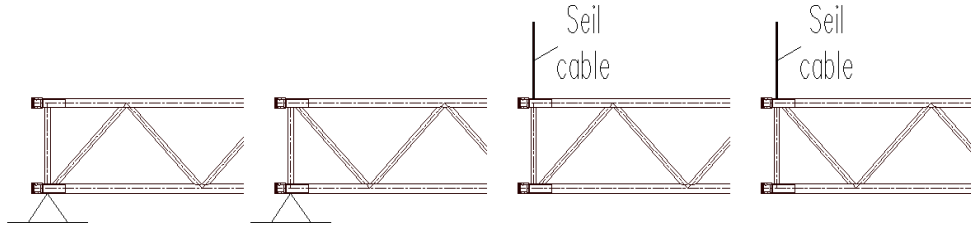



2 SYSTEM

see annex



3 SECTION- AND MATERIAL PROPERTIES

Querschnittswerte Rohre / properties Tubes						
	D	t	A	I	Wel	i
	[mm]	[mm]	[cm ²]	[cm ⁴]	[cm ³]	[cm]
Gurtrohre / main chords	50,0	4	5,78	15,41	6,16	1,63
vertikal Diagonalen / Bracing	25	3	2,07	1,28	1,02	0,79
horizontal Rohre / Lateral tubes	50	4	5,78	15,41	6,16	1,63

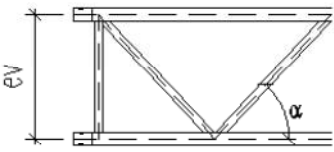
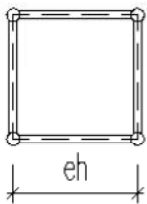
Geometrie Traverse / truss geometry				
				
Achsabstand Gurtrohre	vertical	ev	30,5	[cm]
distance axes main chords	horizontal	eh	54	[cm]
min. Neigung Diagonalen	vertikal	α	34,5	[°]
min. gradient bracing	horizontal	α	90	[°]
Kennwerte Gesamttraverse / properties truss-Section				
A	= 4 x A _G	=	23,12	[cm ²]
I _{yy}	= 4 x I _G + 4 x A _G x (ev/2) ²	=	5438,96	[cm ⁴]
I _{zz}	= 4 x I _G + 4 x A _G x (eh/2) ²	=	16917,65	[cm ⁴]
I _t	= Näherung aus Erfahrungswerten	=	8974,26	[cm ⁴]
i _y	= (I _{yy} /A) ^{1/2}	=	15,34	[cm]
i _z	= (I _{zz} /A) ^{1/2}	=	27,05	[cm]
Index G : Querschnittseigenschaft Gurtrohr section properties main chord				



Material properties

Gurtrohre + Diagonalen		EN AW 6082 T6 (AlMgSi1)	
chords and bracing			
zulässige Spannungen nach EN-1999-1-1 / allowable stress acc. to EN-1999-1-1			
Teilsicherheitsbeiwerte Material / partial safety factors material			
YM1	1,10	Beulklasse / BC	A
YM2	1,25		
0,2%-Dehngrenze / 0,2%-Proof Strength		Zugfestigkeit / ultimate tensile strength	
fo t≤5mm	250 [N/mm ²]	fu t≤5mm	290 [N/mm ²]
fo t>5mm	260 [N/mm ²]	fu t>5mm	310 [N/mm ²]
fo,haz	125 [N/mm ²]	fu,haz	185 [N/mm ²]
Festigkeit der Schweißnaht		fw	190 [N/mm ²]
Strength of welding seams			
Faktor für die WEZ-Werte beim WIG-Schweißen:			0,8
Factor for HAZ-values for TIG-welding:			

Verbinder-Male / Female		EN AW 6061 T6		alternative: steel S45C (C45)	
0,2%-Dehngrenze / 0,2%-Proof Strength		Zugfestigkeit / ultimate tensile strength			
fo	240 [N/mm ²]	fu	290 [N/mm ²]		

Verbinder Bolzen / bolts		10.9			
fyb	900 [N/mm ²]	fub	1000 [N/mm ²]		
Teilsicherheitsbeiwerte Material / partial safety factors material					
YM0	1,00				
YM2	1,25				

Bolzen für Einschubteile / Pins for fittings		S45C (C45)			
---	--	------------	--	--	--



Querschnitts- und Materialeigenschaften der Gurtrohre / Section- and material properties of the chord tubes			
Material	E =	70000	[N/mm ²]
	f _o =	250,00	[N/mm ²]
	f _o /Y _{M1} =	227,27	[N/mm ²]
	f _{o,haz} =	125,00	[N/mm ²]
	f _u =	290,00	[N/mm ²]
	f _u /Y _{M2} =	232,00	[N/mm ²]
	f _{u,haz} =	185,00	[N/mm ²]
	f _{u,haz} /Y _{M2} =	148,00	[N/mm ²]
Querschnitt cross section	D ₀ =	50,00	[mm]
	A =	5,78	[cm ²]
	I =	15,41	[cm ⁴]
	i =	1,63	[cm]
Bestimmung der QS-Klasse Determination of section-class	β =	10,61	[-]
	ε =	1,00	[-]
	QS-Klasse =	1	
			3 · (D ₀ / t) ^{0,5} nach 6.10 (250 / fo) ^{0,5} nach Kap. 6.1.4.4 acc. chapter 6.1.4.4
Beiwerte Biegeknicken Coefficients for buckling	BC =	A	[-]
	α =	0,20	[-]
	λ ₀ =	0,10	[-]
teff im Bereich der WEZ teff in heat affected zone	red Faktor =	0,8	[-] (WIG TIG)
	Knotenpunkt mit 1 Diagonalen / node with 1 bracing		
	D1 =	25,00	[mm]
	U _{WEZ} =	85,00	[mm] D1 + 2 · 30
	U _{Total} =	157,08	[mm]
	teff,o/t =	0,68	[-] [1 - (1 - red-Faktor · f _{o,haz} / fo) · U _{WEZ} / U _{Total}]
	teff,u/t =	0,74	[-] [1 - (1 - red-Faktor · f _{u,haz} / fu) · U _{WEZ} / U _{Total}]
	Knotenpunkt mit 2 Diagonalen / node with 2 bracing		
	D1 =	25,00	[mm]
	D2 =	50,00	[mm]
	U _{WEZ} =	151,04	[mm] π / 2 · D ₀ + D1 / 2 + 2 · 30
	U _{Total} =	157,08	[mm]
	teff,o / t =	0,42	[-] [1 - (1 - red-Faktor · f _{o,haz} / fo) · U _{WEZ} / U _{Total}]
	teff,u / t =	0,53	[-] [1 - (1 - red-Faktor · f _{u,haz} / fu) · U _{WEZ} / U _{Total}]

Querschnitts- und Materialeigenschaften der vert. Diagonalen / Section- and material properties of the vert. bracing			
Material	E =	70000	[N/mm ²]
	f _o =	250,00	[N/mm ²]
	f _o /Y _{M1} =	227,27	[N/mm ²]
	BC =	A	[-]
	α =	0,20	[-]
	λ ₀ =	0,1	[-]
Querschnitt / cross section	D ₀ =	25	[mm]
	A =	2,07	[cm ²]
	I =	1,28	[cm ⁴]
	i =	0,79	[cm]



4 ALLOWABLE LOADING SINGLE COMPONENTS

Gurtrohr im Bereich der WEZ an der Kupplung main chord in heat affected zone at coupler			
$NR_d = A \times 0,8^* \times f_{u,haz} / Y_{M2}$	=	68,44 [kN]	*(WIG τ_{IG}) örtliche Schweißnaht nach Kap. 6.2.9.3 (1) local welding seam acc. chapter 6.2.9.3 (1)
Gurtrohr auf Druck an der Kupplung im Bereich der Spannstifte in der WEZ main chord at coupler under pressure at pins at HAZ			
d,pins	=	15 [mm]	
A,net	=	4,58 [cm ²]	
$NR_d = A_{,net} \times 0,8^* \times f_{u,haz} / Y_{M2}$	=	54,23 [kN]	nach Gl. 6.21a acc. equation 6.21a
Gurtrohr auf Zug an der Kupplung im Bereich der Spannstifte in der WEZ mit 2 Diagonalen main chord at coupler under tension at pins at HAZ with 2 bracings			
d,pins	=	15 [mm]	
A,net	=	4,58 [cm ²]	
$NR_d = A_{,net} \times 0,8^* \times f_{u,haz} / Y_{M2}$	=	54,23 [kN]	nach Gl. 6.19a Faktor 0,9 nicht angesetzt wg. Verstärkung durch Diagonale acc. equation 6.19a factor 0,9 not taken into acc. due to strengthening by bracing
Gurtrohr im Bereich der WEZ ohne Spannstifte main chord in heat affected zone without pins			
Knotenpunkt mit 1 Diagonalen / node with 1 bracing			
$NR_d = A_{u,eff} \times f_u / Y_{M2}$ (mit $A_{u,eff} = t_{eff,u} / t \times A$)	=	98,57 [kN]	nach Gl. 6.19b acc. equation 6.19b
Knotenpunkt mit 2 Diagonalen / node with 2 bracing			
$NR_d = A_{u,eff} \times f_u / Y_{M2}$ (mit $A_{u,eff} = t_{eff,u} / t \times A$)	=	70,97 [kN]	nach Gl. 6.19b acc. equation 6.19b
Knicken Gurtrohr zw. Knoten ohne Diagonale in der Mitte buckling main chord between nodes without bracing in the middle			
sk	=	76,50 [cm]	
N _{cr}	=	181,86 [kN]	
λ^*	=	0,89 [-]	
ϕ	=	0,98 [-]	
X	=	0,73 [-]	
κ	=	1,00 [-]	
$NR_d = \kappa \times X \times A \times f_o / Y_{M1}$	=	95,55 [kN]	nach Gl. 6.49a acc. equation 6.49a

relevant for main chord tubes:

$NR_{dG} = 54,23$ kN



Bending of the center 50x4 mm tubes:

Lokale Biegung Gurtrohr Knotenpunkt vollst. in WEZ Local bending of chord			
örtliche Schweißnaht nach Kap. 6.2.9.3 (1) local welding seam acc. Chapter 6.2.9.3 (1)			
	D =	50	[mm]
	red Faktor =	0,8	[-] (WIG TIG)
	$\rho_{u,haz}$ =	0,64	[-] $f_{u,haz} / f_u$
	$t_{u,eff}$ =	2,04	[mm] red-Faktor $\cdot \rho_{u,haz} \cdot t$
	$W_{net} = \pi \times R^2 \times t_{u,eff}$ =	3,39	[cm ³] mit $R = D / 2 - t / 2$
	$MuRd = W_{net} \cdot f_u / yM2$	=	78,71 [kNcm] nach Gl. 6.24 acc. equation 6.24

Lokale Biegung Gurtrohr Knotenpunkt vollst. in WEZ Local bending of chord			
örtliche Schweißnaht nach Kap. 6.2.9.3 (2) local welding seam acc. Chapter 6.2.9.3 (2)			
	α =	0,55	[-] nach Tab. 6.4
Nebenrechnung QS-Kl. 3 Auxiliary calculation for class 3			
	D =	50,0	[mm]
	red Faktor =	0,8	[-] (WIG TIG)
	$\rho_{o,haz}$ =	0,5	[-] $f_{o,haz} / f_o$
	$t_{o,eff}$ =	1,60	[mm] $t_{eff,o} / t \cdot t$
	$W_{el,haz} = \pi \times R^2 \times t_{o,eff}$ =	2,66	[cm ³] mit $R = D / 2 - t / 2$
	W_{el} =	6,16	[cm ³]
	$W_{pl,haz} = 4 \times R^2 \times t_{o,eff}$ =	3,39	[cm ³] mit $R = D / 2 - t / 2$
	β_3 =	18	nach Kaj nach Kap. 6.1.4.4
	β_2 =	13	nach Kaj nach Kap. 6.1.4.4
	$\alpha_{,3w}$ =	0,64	[-]
	$MoRd = \alpha \cdot W_{el} \cdot f_o / yM1$	=	76,95 [kNcm] nach Gl. 6.24 acc. equation 6.24

Bracing

Diagonale im Bereich der WEZ bracing in heat affected zone			
	$NRd = A \times 0,8^* \times f_{u,haz} / YM2$	=	24,55 [kN] *(WIG TIG) Querschweißnaht nach Kap. 6.2.9.3 (1) local welding seam acc. chapter 6.2.9.3 (1)
Knicken Diagonale buckling bracing			
	sk =	49,00	[cm]
	Ncr =	36,77	[kN]
	λ^* =	1,19	[-]
	ϕ =	1,31	[-]
	X =	0,53	[-]
	$NRd = X \times A_G \times f_o / YM1$	=	25,12 [kN] nach Gl. 6.49a acc. equation 6.49a
Schweißnaht zwischen Diagonale und Gurtrohr welding seam between chord and female conical coupler			
	f _w =	190,00	[N/mm ²]
	Y _{mw} =	1,25	[-]
	$NRd = A \times f_w / YM1$	=	31,52 [kN] nach Gl. 8.29 acc. equation 8.29

relevant for bracing tubes:

NR_D = 24,55 kN



Allowable normal force at coupler:

Bolzen / Bolt					
Material	10.9	f_{yb}	=	90,00	[kN/cm ²]
		f_{ub}	=	100,00	[kN/cm ²]
Geometrie		D_b	=	1,59	[cm]
geometry		A_b	=	1,98	[cm ²]
zul. Normalkraft aus Abscheren n. EN 1993-1-8: allow able loading due to shearing acc. to EN 1993-1-8:					
		$N_{Rd} = 2 \times 0,60 \times A_b \times f_{ub} / Y_{M2}$	=	190,14	[kN]
Biegung des Bolzens in Anlehnung an EN 1993-1-8 Kap. 3.13.2 bending of the bolt acc. to EN 1993-1-8 chapter 3.13.2					
		$M_{Rd} = 1,5 \times W_{el} \times f_{yb} / Y_{M0}$	=	53,07	[kNcm]
Kombination Biegung und Abscheren n. EN 1993-1-8 combination of bending and shearing acc. to EN 1993-1-8					
		a	=	1,23	[cm]
		b	=	1,59	[cm]
		c	=	0,08	[cm]
		$M_{Ed} = N/8 \times (b + 4c + 2a)$ (Ansatz M_{ed} auf der sicheren Seite liegend) $(M_{Ed}/M_{Rd})^2 + (F_{Ed}/F_{Rd})^2 \leq 1$	=	0,54	x N [kNcm]
		→	N_{Rd}	=	86,71 [kN]
Verbinder / male fitting					
Material		EN AW 6061 T6			
Geometrie		D_m	=	15,88	[mm]
geometry					
Lochleibung in Anlehnung an EN 1999-1-1 Kap. 8.5.5 Bearing Stress acc. to EN 1999-1-1 Chapter 8.5.5					
		f_u / Y_{M2}	=	232,00	[N/mm ²]
		d_o	=	15,88	[mm]
		t	=	15,88	[mm]
		e_1	=	25	[mm]
		α_b	=	0,525	[-]
		e_2	=	24	[mm]
		k_1	=	2,5	[-]
		$N_{rd} = k_1 \times \alpha_b \times f_u \times d \times t / Y_{M2}$	=	76,75	[kN]



Pins for fitting

2 pins $\varnothing 14,5$ mm

Steel S45C

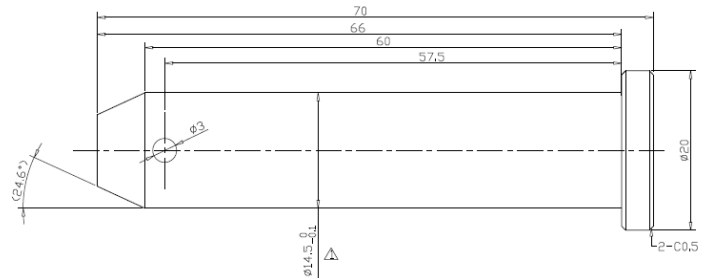

Shearing resistance

$$f_u \geq 650 \text{ N/mm}^2$$

$$F_{v,Rd} = 0,6 \cdot 65 \cdot \pi \cdot (1,45/2)^2 / 1,25 = 51,5 \text{ kN}$$

per shear plane

2 pins per coupler => 4 shear planes

$$N_{Rd} = 4 \cdot 51,5 = 206 \text{ kN}$$

Chord

$\varnothing 50 \times 4$ mm

Aluminium EN AW 6082 T6

Bearing of holes

holes $\varnothing 15$ mm completely in het affected area

$$e_1 \geq 50 \text{ mm}$$

$$p_2 \geq 50 \text{ mm}$$

$$k_1 = 1,4 \cdot 50 / 15 - 1,7 > 2,5$$

$$\alpha_b = 50 / 3 / 15 > 1,0$$

$$f_{u,haz} = 185 \text{ N/mm}^2$$

reduction factor 0,8

$$F_{b,Rd} = 2,5 \cdot 1,0 \cdot 1,45 \cdot 2 \cdot 0,4 \cdot 0,8 \cdot 18,5 / 1,25$$
$$= 34,3 \text{ kN per pin}$$

2 pins per coupler

$$N_{Rd} = 2 \cdot 34,3 = 68,6 \text{ kN}$$



Fitting

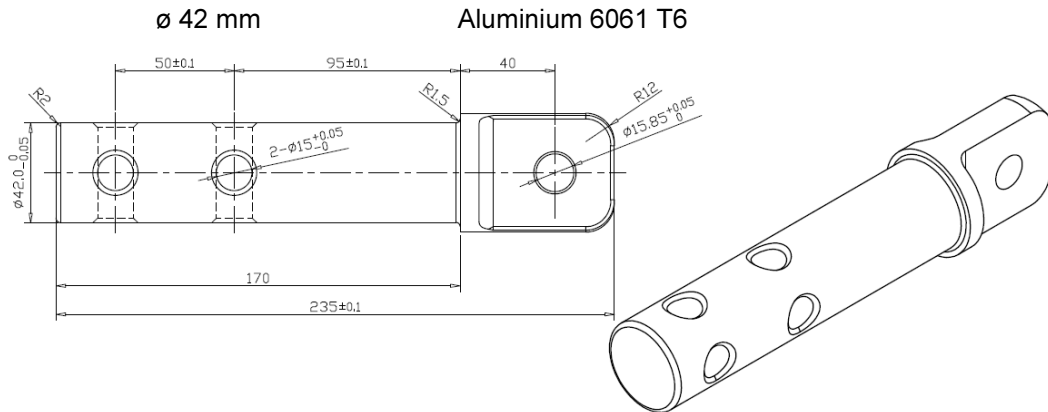

Bearing of holes

holes $\phi 15$

$e_1 \geq 20 \text{ mm}$

$e_2 \geq 20 \text{ mm}$

$$k_1 = 2,8 \cdot 20 / 15 - 1,7 = 2,0$$

$$\alpha_b = 20 / 3 / 15 = 0,44$$

Steel C45 $f_u \geq 630 \text{ N/mm}^2$

Alu 6061T6 $f_u \geq 290 \text{ N/mm}^2$

$$F_{b,Rd,Steel} = 2,0 \cdot 0,44 \cdot 1,45 \cdot 4,2 \cdot 63 / 1,25 \\ = 270 \text{ kN per pin}$$

$$F_{b,Rd,Alu} = 2,0 \cdot 0,44 \cdot 1,45 \cdot 4,2 \cdot 29 / 1,25 \\ = 124 \text{ kN per pin}$$

2 pins per coupler

$$N_{Rd} = 2 \cdot 124 = 248 \text{ kN}$$

Remaining
Cross-section

$$A_{net} = \pi \cdot 2,1^2 - 2 \cdot 1,5 \cdot 4,2 + 1,5^2 = 3,5 \text{ m}^2$$

Alu 6061T6 $f_o \geq 240 \text{ N/mm}^2$

$$F_{t,Rd,Alu} = 3,5 \cdot 24 / 1,1 = 76 \text{ kN}$$

$$N_{Rd} = 76 \text{ kN}$$



Interaction bending and normal force at coupler of the outer chords

Verification of interaction bending and normal force at coupler

$$\Rightarrow (Nsd_G / NRd_G)^{1,3} + (Msd_G / MRd_G) < 1,0$$

mit $Nsd_G = Nsd / 4 + Msd / (2 \cdot 0,35 \text{ m})$

und $Msd_G = 0,25 \cdot Qsd \cdot 8,0 \text{ cm} = 2,0 \text{ cm} \cdot Qsd$

$\Rightarrow a = \text{factor for cantilever at the coupler} = 2,0 \text{ cm}$

Nsd, Msd und Qsd : global internal forces in the truss (in kN resp. kNm)

The global internal forces include the following safety factors acc. Eurocode:

selfweight of the truss: $yF = 1,35$

Net load on the truss: $yF = 1,50$

NRd_G = allowable loading of the chord in the heat affected zone (see following table):

Gurtrohr auf Druck an der Kupplung im Bereich der Spannstifte in der WEZ main chord at coupler under pressure at pins at HAZ				
d,pins	=	15	[mm]	
A _{,net}	=	4,58	[cm ²]	
$NRd = A_{,net} \times 0,8^* \times f_{u,haz} / \gamma_{M2}$	=	54,23	[kN]	nach Gl. 6.21a acc. equation 6.21a

$MRd_G = MuRd$ (see following table):

Lokale Biegung Gurtrohr Knotenpunkt vollst. in WEZ Local bending of chord				
örtliche Schweißnaht nach Kap. 6.2.9.3 (1) local welding seam acc. Chapter 6.2.9.3 (1)				
D	=	50	[mm]	
red-Faktor	=	0,8	[-]	(WIG TIG)
$\rho_{o,haz}$	=	0,64	[-]	$f_{u,haz} / f_u$
$t_{u,eff}$	=	2,04	[mm]	red-Faktor $\cdot \rho_{o,haz} \cdot t$
$W_{net} = \pi \times R^2 \times t_{u,eff}$	=	3,39	[cm ³]	mit $R = D / 2 - t / 2$
$MuRd = W_{net} \cdot f_u / \gamma_{M2}$	=	78,71	[kNcm]	nach Gl. 6.24 acc. equation 6.24



The following 2 cases are taken into account.

1. Verification of the center chords at the top at UDL-loads or multiple single point loads

The center chord at the botto are loaded at the worst points with multiple single point loads at a distance of 50 cm between each load.

2. Verification of the outer chords with uniformly distributed load (UDL)

The coupler is always located at the theoretically worst point. This results from the following extremum-calculation:

Note: For the determination of the worst position of the coupler, the exponent 1,3, for the relation of actual load to the allowable load is not taken into account with sufficient accuracy.

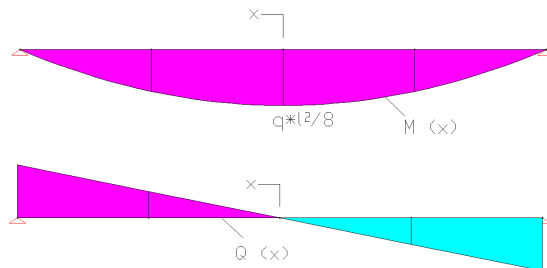

$$M_{sd}(x) = q_{sd} \cdot L^2 / 8 - q_{sd} \cdot x^2 / 2$$

$$Q_{sd}(x) = q_{sd} \cdot x$$

$$NR_{dG} = 58,97 \text{ kN}$$

$$MR_{dG} = 78,71 \text{ kNcm}$$

$$M\text{-}Q \text{ Interaction} \quad M_{sd}(x) / (2 \cdot 0,305 \cdot 54,23) + Q_{sd}(x) \cdot 2,0 / 78,71$$

$$\text{Extreme value:} \quad d/dx \sigma(x) = 0$$

$$\Rightarrow x = 2 \cdot 0,305 \cdot 54,23 \cdot 2,0 / 78,71 = 0,841 \text{ m}$$

(from middle of span)



Summary

Following points are relevant for the determination of the allowable loads:

1. Allowable bending moment of the center chord at the top and the cross tubes (MR_{dG}) $\Rightarrow MR_{dG} = 76,95 \text{ kNcm}$
2. Allowable normal force in main chord (NR_{dG})
Main chord in heat affected zone at coupler is relevant $\Rightarrow NR_{dG} = 54,23 \text{ kN}$
3. Global shear force in truss (Q)
Allowable normal force in diagonals at nodes is relevant $\Rightarrow NR_{dD} = 24,55 \text{ kN}$

zul shear force from $QR_d / (2 \cdot \sin 34,5^\circ) < 0,9 \cdot NR_{dD}$
* 10% reduction because of minor stresses
 $\Rightarrow \text{allow. } QR_d = 0,9 \cdot 24,55 \cdot 2 \cdot \sin 34,5^\circ \Rightarrow QR_d = 25,03 \text{ kN}$
4. Interaction bending and normal force at coupler \Rightarrow see page 12



5 ALLOWABLE LOADING SINGLE SPAN GIRDER

5.1 Center chords at top

Systems [cm]:

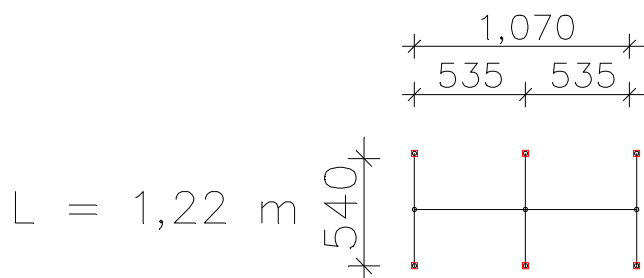
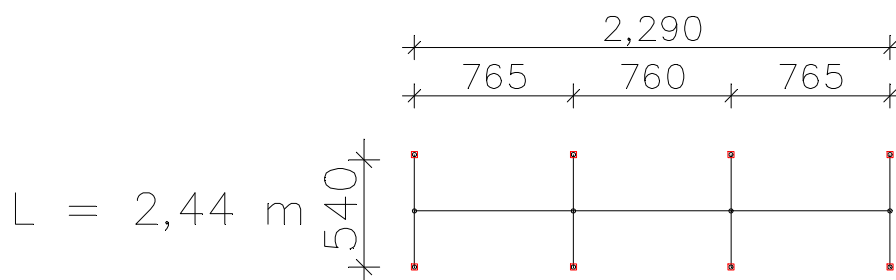
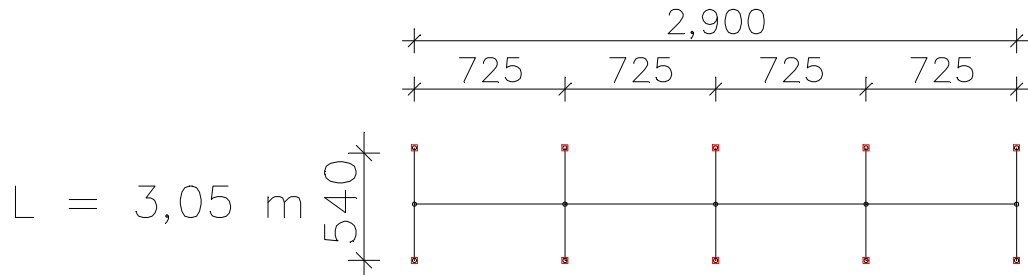

Loadings:

Multiple point loads at a distance of 50 cm

$P_i = 2,0 \text{ kN}$ see following pages

Calculation

see following pages

Verification:

$\max M_{Ed} = 1,5 \cdot 49 \text{ kNcm} = 73,5 \text{ kNcm}$

$< MR_d = 76,95 \text{ kNcm}$



20.11.2019

M 1 :

Systemkenngrößen

- 36 Knoten
- 33 Stäbe
- 24 Festhaltungen
- 0 Koppelungen
- 1 Materialkennwerte
- 1 Querschnittswerte
- 5 Lastfälle
- 1 LF-Kombinationen
- 7 Ergebnisorte in den Stäben

Querschnittswerte

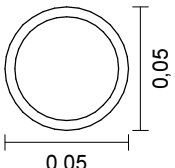
1	Polygon 	Schwerpunkt [m]	ys = 0,000	zs = 0,000
		Fläche [m²]	A = 5,7435e-04	
		Trägheitsmomente [m4]	lx = 1,0000e-06	
			ly = 1,5208e-07	l1 = 1,5208e-07
			lz = 1,5208e-07	l2 = 1,5208e-07
		Hauptachsenwinkel [Grad]	Phi = 0,000	lyz = 0,0000e+00
		Mittelung der Querkraft-Schubspannungen über die Qu.-breite		

Materialkennwerte

Nr.	Art	E-Modul [MN/m²]	G-Modul [MN/m²]	alpha.t [1/K]	gamma [kN/m³]	Verschiedenes
1	1 Frei	70000	27000	1,0e-05	27,000	fc = 1e+06 [MN/m²] ft = 1e+06



20.11.2019

M 1 :

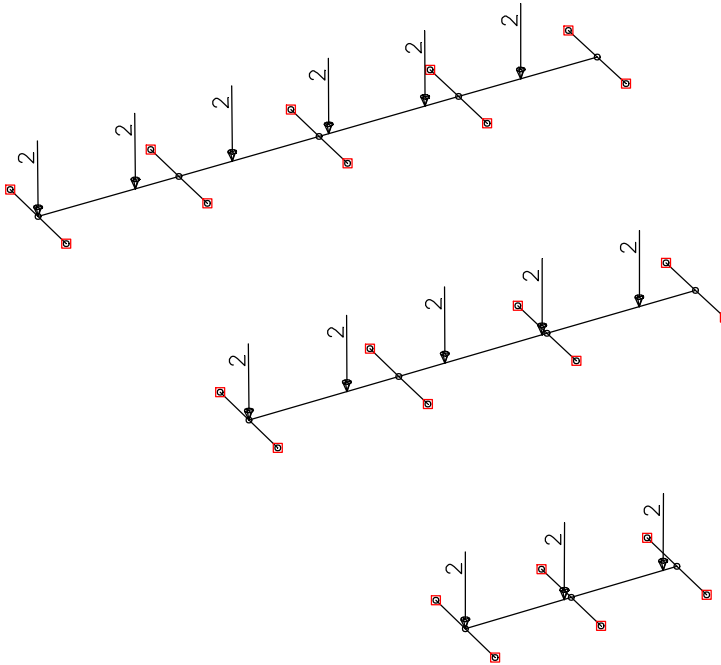
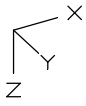

LF 60: Belastung, p1

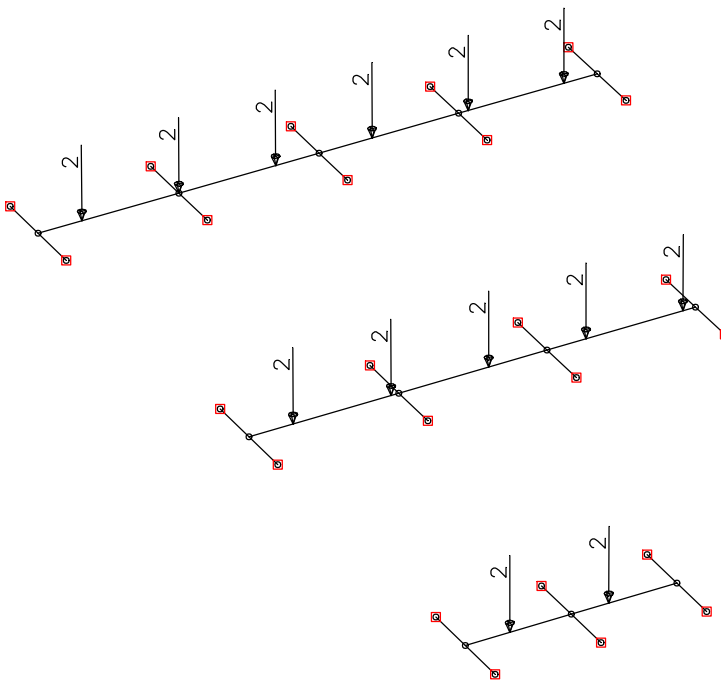
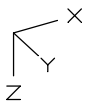

LF 61: Belastung, p2



20.11.2019

M 1 :

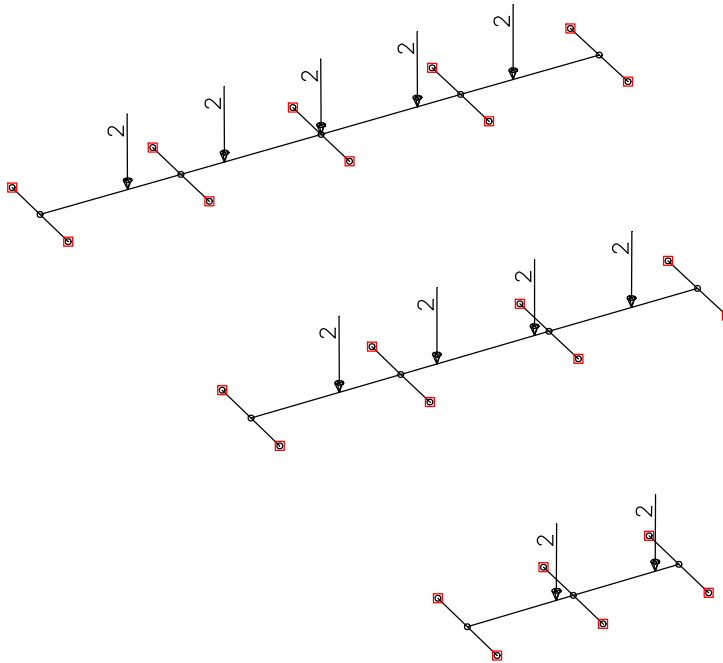
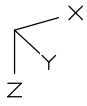

LF 62: Belastung, p3

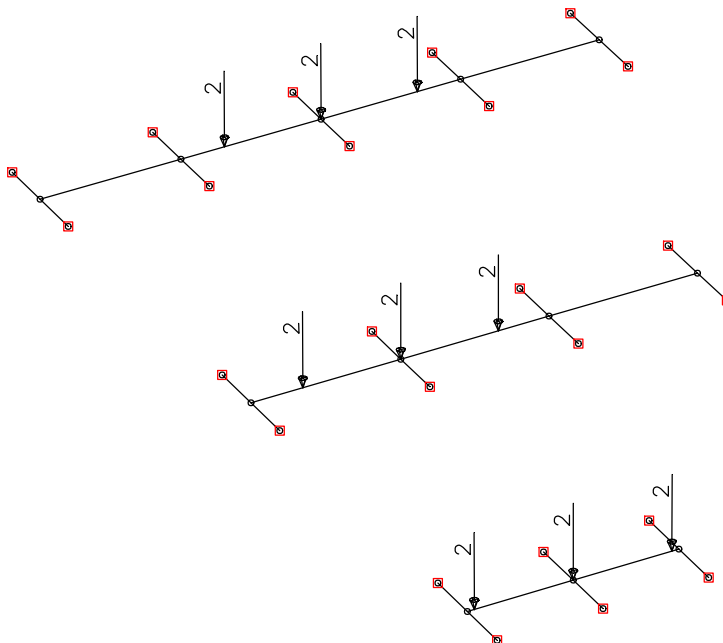
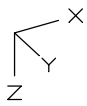

LF 63: Belastung, p4



20.11.2019

M 1 :

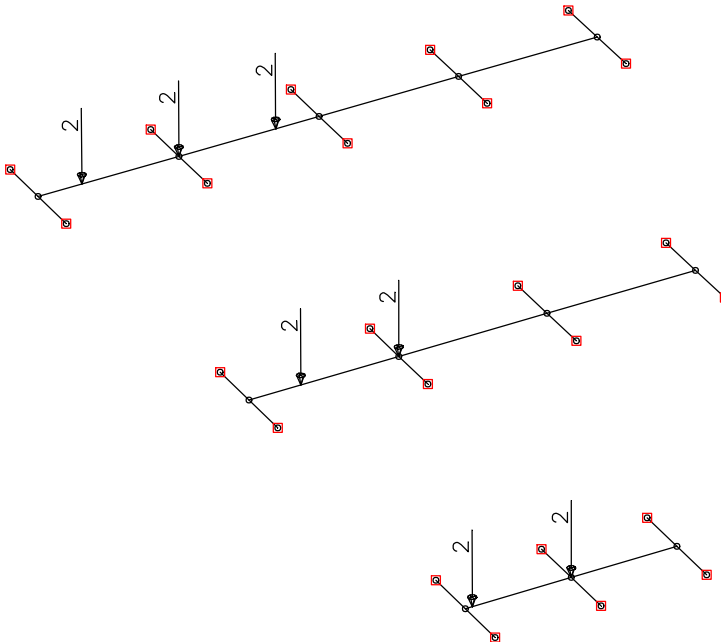
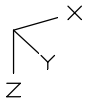

LF 64: Belastung, p5

Lastfallkombination 1

Exklusive Auswahl		Faktor
60	p1	1,000
61	p2	1,000
62	p3	1,000
63	p4	1,000
64	p5	1,000

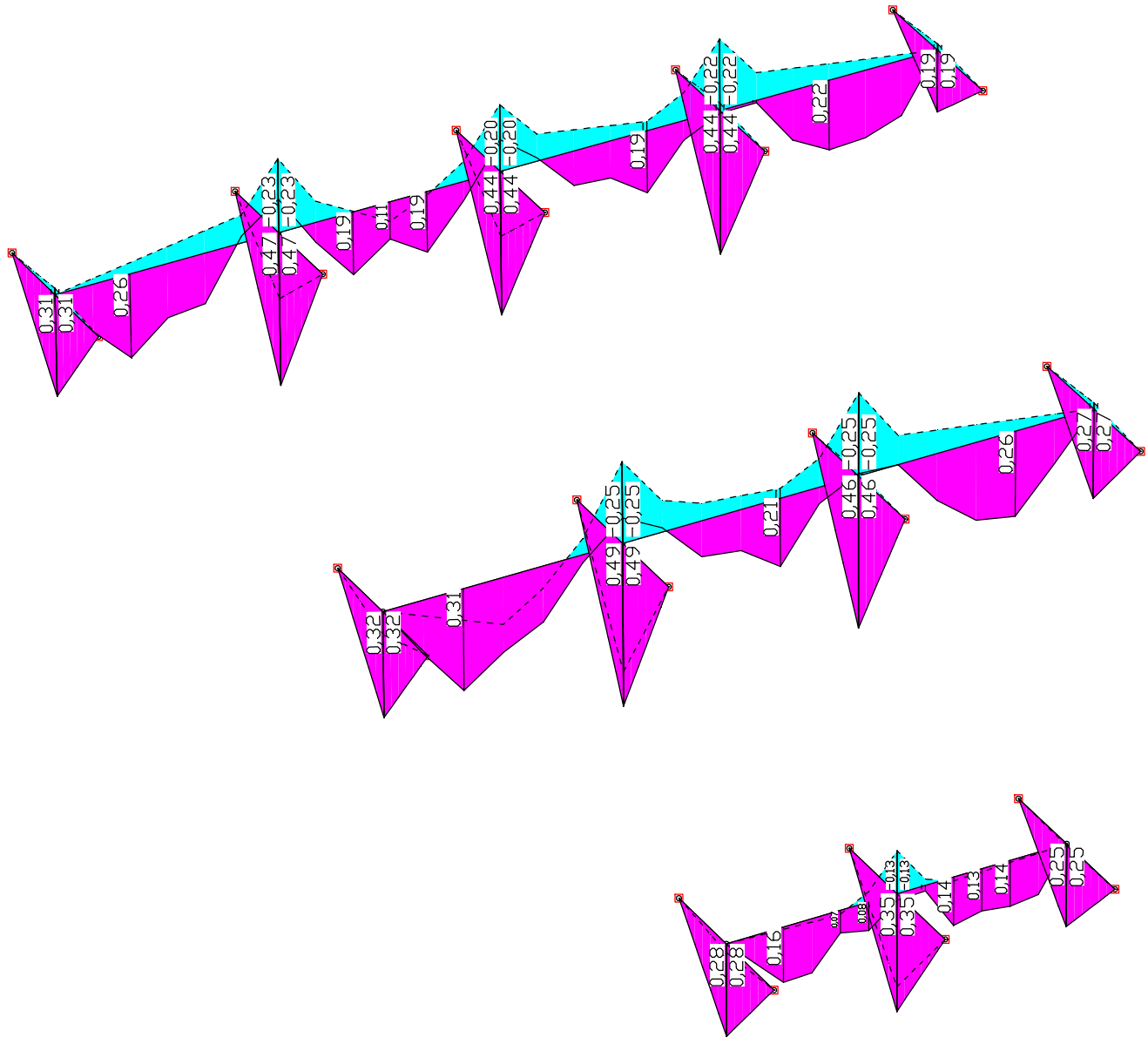
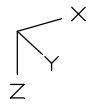

LFK 1: Schnittgrößen min,max My [kNm]

Wertebereich (Gesamtsystem, min/max): -0,25/0,49 [kNm]



5.2 Outer chords + bracing uniformly distributed load (UDL)

System:

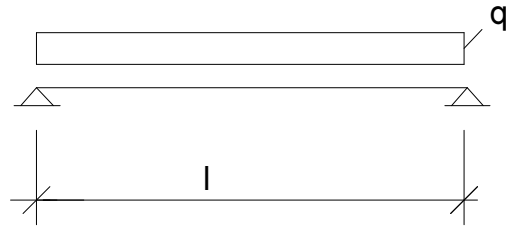

Loading

$$q_{sd} = p_{sd} + g_{sd}$$

(Net load + selfweight, incl. safety factors)

Normal force in chords:

$$NR_d \geq q_{sd} \cdot L^2 / 8 / (n \cdot b)$$

$$\Rightarrow q_{sd} \leq NR_d \cdot (n \cdot b) \cdot 8 / L^2$$

$$\Rightarrow \text{zul } p = (NR_d \cdot (n \cdot b) \cdot 8 / L^2 - g_{sd}) / \gamma_F$$

Normal force in bracing:

$$QR_d \geq q_{sd} \cdot L / 2$$

$$\Rightarrow q_{sd} \leq QR_d \cdot 2 / L$$

$$\Rightarrow \text{zul } p = (QR_d \cdot 2 / L - g_{sd}) / \gamma_F$$

Interaction at coupler:

Verification of interaction bending and normal force at coupler by an iterative method.

$$\Rightarrow (N_{sdG} / NR_{dG})^{1,3} + (M_{sdG} / MR_{dG}) < 1,0$$

applied: The coupler is located at $e = 0,841$ m from the middle of the span (theoretically worst point, see extremum-calculation in chapter 4)

Loading table:

Gleichstreckenlast

Uniformly distributed load UDL

zulässige Belastung in Abhängigkeit von				
allowable load as a function of				
	NR _d	QR _d	Interaction at coupler	Center chord at bottom
L [m]	zul q [kN/m]	zul q [kN/m]	zul q [kN/m]	zul q [kN/m]
4,00	10,88	8,20	9,80	4,00
5,00	6,91	6,53	6,46	4,00
6,00	4,75	5,42	4,54	4,00
7,00	3,45	4,62	3,34	4,00
8,00	2,61	4,02	2,54	4,00
9,00	2,03	3,56	1,99	4,00
10,00	1,62	3,19	1,59	4,00
11,00	1,31	2,89	1,29	4,00
12,00	1,08	2,63	1,07	4,00
13,00	0,90	2,42	0,89	4,00
14,00	0,75	2,24	0,75	4,00
15,00	0,64	2,08	0,63	4,00
16,00	0,54	1,94	0,54	4,00
17,00	0,46	1,82	0,46	4,00
18,00	0,40	1,71	0,40	4,00
19,00	0,34	1,61	0,34	4,00
20,00	0,29	1,52	0,29	4,00
21,00	0,25	1,44	0,25	4,00
22,00	0,22	1,37	0,22	4,00
23,00	0,19	1,30	0,19	4,00
24,00	0,16	1,24	0,16	4,00

Loadings > 4 kN/m are not allowed acc. chapter 5.1!



6 SUMMARY OF RESULTS

6.1 Allowable loadings:

Spannweite	UDL	
Span	UDL	
[m]	[kN/m]	
4	4,00	*
5	4,00	*
6	4,00	*
7	3,34	
8	2,54	
9	1,99	
10	1,59	
11	1,29	
12	1,07	
13	0,89	
14	0,75	
15	0,63	
16	0,54	
17	0,46	
18	0,40	
19	0,34	
20	0,29	
21	0,25	
22	0,22	
23	0,19	
24	0,16	

***The allowable loading is limited by the local load transfer on central top chord (Chapter 1.4 - First condition)**

The values of the table are only valid for single-span girder.

The truss-elements have to be braced with diagonals.

Loads have to be applied at the center chords of the top.

Loads at the middle of the couplers are not allowed.

The specified values include partial safety coefficients on the loadings side acc. EN 1990 of $\gamma_F = 1.50$ for payloads and $\gamma_G = 1.35$ for selfweight of the truss.

For applications which can be calculated on the basis of other codes, the partial safety factors can be adjusted (for example temporary structures acc. EN 13814, $\gamma_F = 1.35$ for payloads).

To use the resulting allowable loads with British Standard (BS) and ANSI, allowable loads listed in tables have to be multiplied by 0.85.



6.2 Deflections at max. allowable loadings:

Vorhandene Durchbiegung [cm] Prerig-Truss unter max. zul. Lasten

Deflections [cm] for Prerig-Truss at max. allowable loads

Spannweiten	UDL
Span	UDL
[m]	[cm]
4	0,36
5	0,89
6	1,85
7	2,87
8	3,79
9	4,83
10	6,00
11	7,29
12	8,71
13	10,26
14	11,95
15	13,77
16	15,72
17	17,81
18	20,04
19	22,42
20	24,93
21	27,60
22	30,41
23	33,38
24	36,50

 = deflection $\geq L/100$

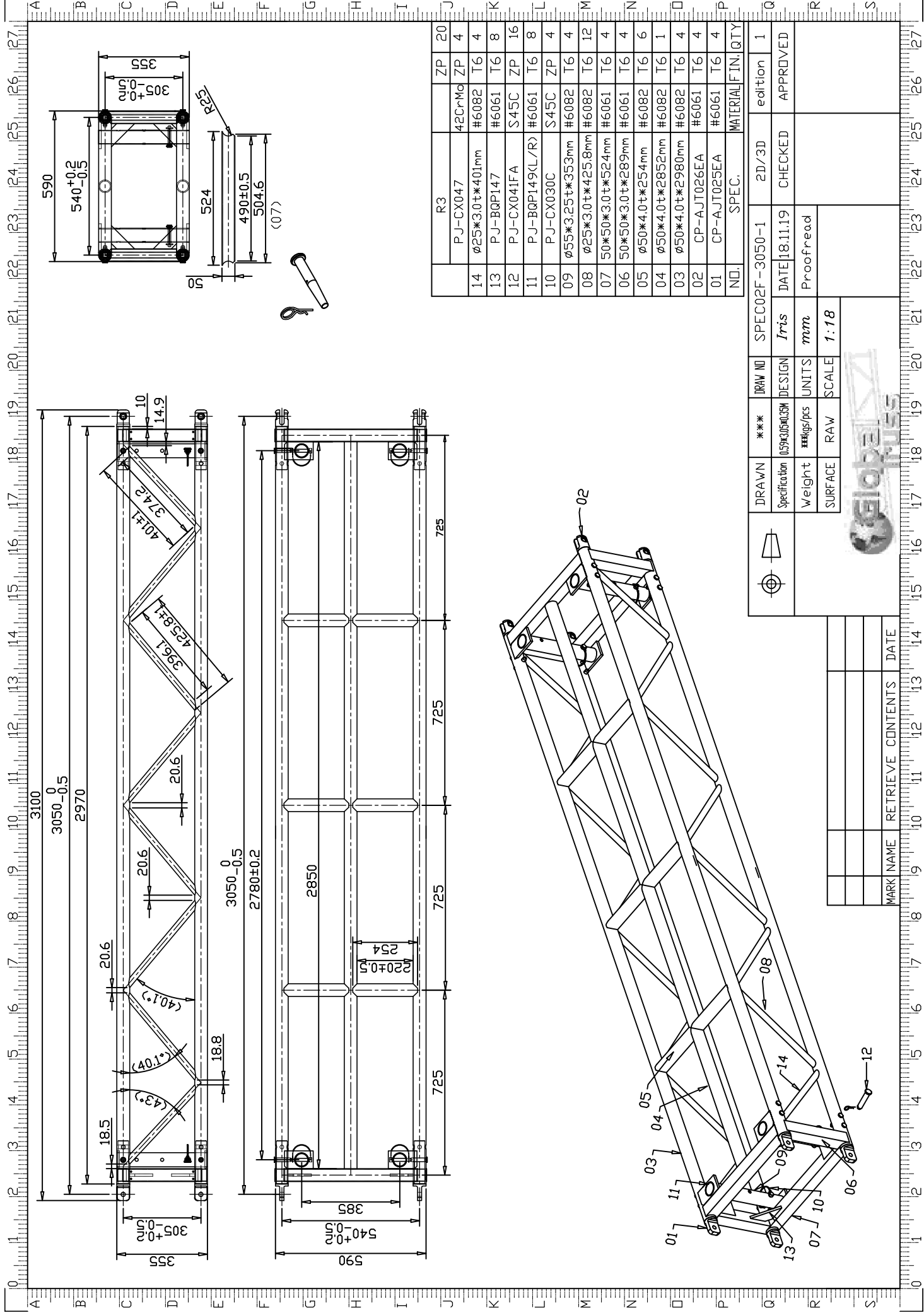

DRAWN	***	IRAW NO	SPEC Q2F-3050-1	2D/3D	edition
Specification	0599305035M	DESIGN	DATE 18.11.19	CHECKED	APPROVED
Weight	**kgs/pcs	UNITS	Proofread		
SURFACE	RAW	SCALE	1:18		

MARK NAME	RETRIEVE	CONTENTS	DATE



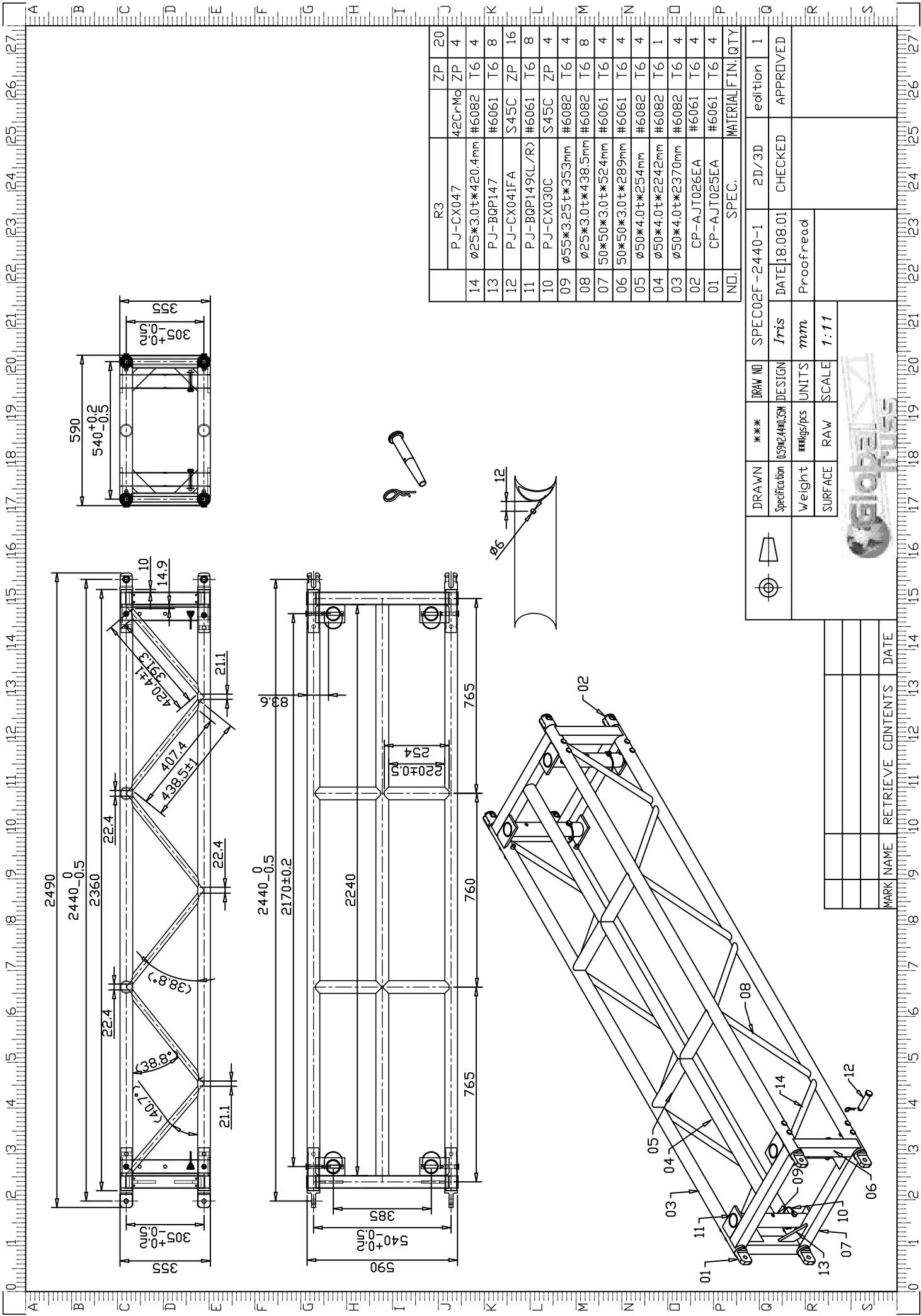

NO.	SPEC.	QTY	UNIT
14	PJ-CX047	42CrMo	ZP 4
13	PJ-BQP147	#6082	T6 4
12	PJ-CX04IFA	S45C	ZP 16
11	PJ-BQP149(L/R)	#6061	T6 8
10	PJ-CX030C	S45C	ZP 4
09	Ø55*3.25t*353mm	#6082	T6 4
08	Ø25*3.0t*438.5mm	#6082	T6 8
07	50*50*3.0t*52.4mm	#6061	T6 4
06	50*50*3.0t*289mm	#6061	T6 4
05	Ø50*4.0t*25.4mm	#6082	T6 4
04	Ø50*4.0t*22.42mm	#6082	T6 1
03	Ø50*4.0t*23.70mm	#6082	T6 4
02	CP-AJT026EA	#6061	T6 4
01	CP-AJT025EA	#6061	T6 4

DRAWN	***	IRAW NO	SPEC Q2F-2440-1	2D/3D	edition
Specification	0592440.35M	DESIGN	DATE 18.08.01	CHECKED	APPROVED
Weight	**kgs/pcs	UNITS	Proofread		
SURFACE	RAW	SCALE	1:11		

MARK NAME	RETRIEVE	CONTENTS	DATE



A 0 1 2 3 4 5 6 7 8 9 10 11 12 13 14 15 16 17 18 19 20 21 22 23 24 25 26 27

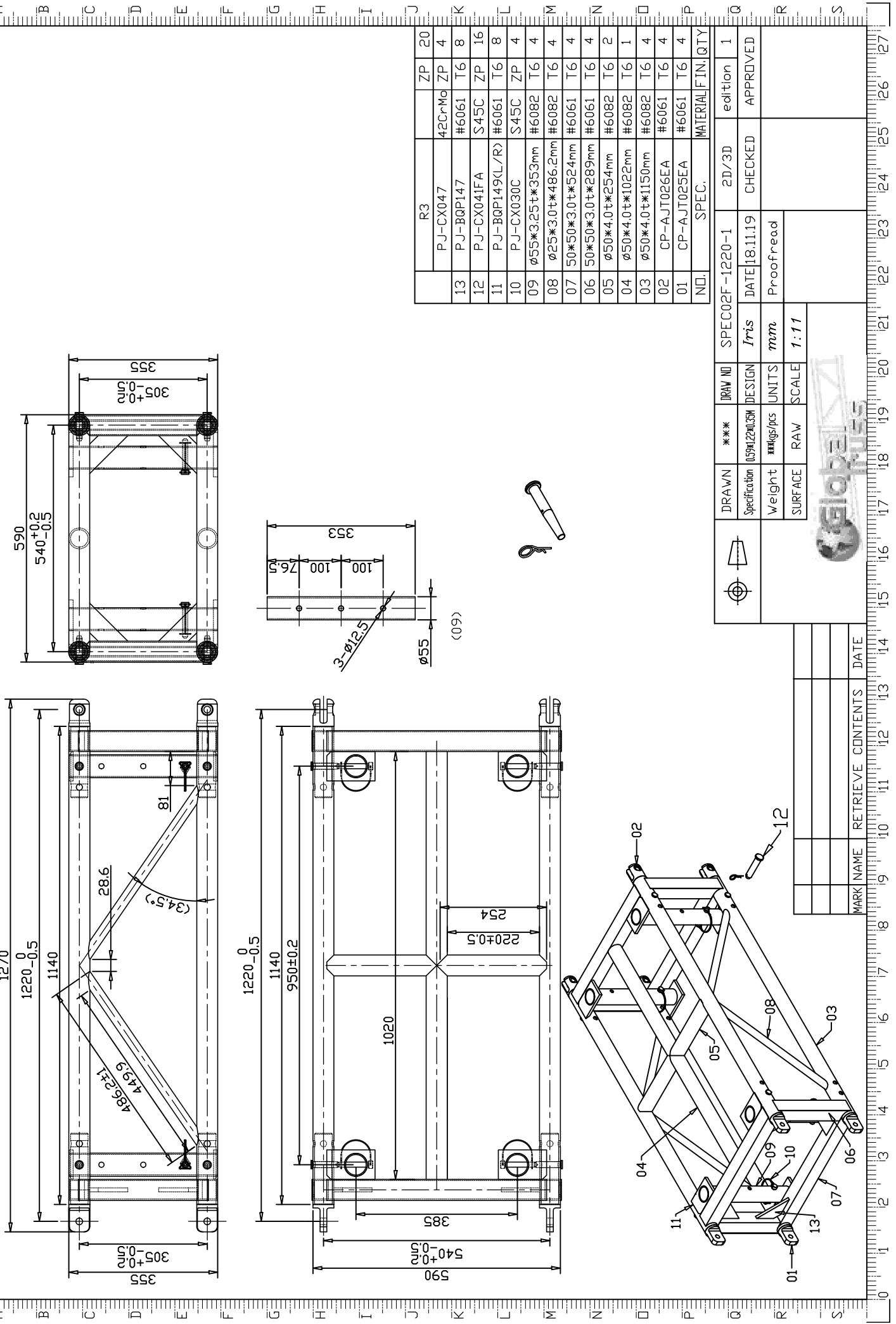

R3		ZP	ZP
13	PJ-CX047	42CrMo	ZP 4
12	PJ-BQP147	#6061	T6 8
11	PJ-CX04IFA	S45C	ZP 16
10	PJ-BQP149(L/R)	#6061	T6 8
09	PJ-CX030C	S45C	ZP 4
08	Ø55*3.25t*353mm	#6082	T6 4
07	Ø25*3.0t*486.2mm	#6082	T6 4
06	50*50*3.0t*524mm	#6061	T6 4
05	50*50*3.0t*289mm	#6061	T6 4
04	Ø50*4.0t*254mm	#6082	T6 2
03	Ø50*4.0t*1022mm	#6082	T6 1
02	Ø50*4.0t*1150mm	#6082	T6 4
01	CP-AJT026EA	#6061	T6 4
	CP-AJT025EA	#6061	T6 4
ND.	SPEC.	MATERIAL	FIN. QTY

DRAWN	***	DRAW NO	SPEC02F-1220-1
Specification	05941220030H	DESIGN	DATE 18.11.19
Weight	**kgs/pcs	UNITS	Proofread
SURFACE	RAW	SCALE	1:1.1

2D/3D CHECKED APPROVED

edition 1

MARK NAME	RETRIEVE	CONTENTS	DATE



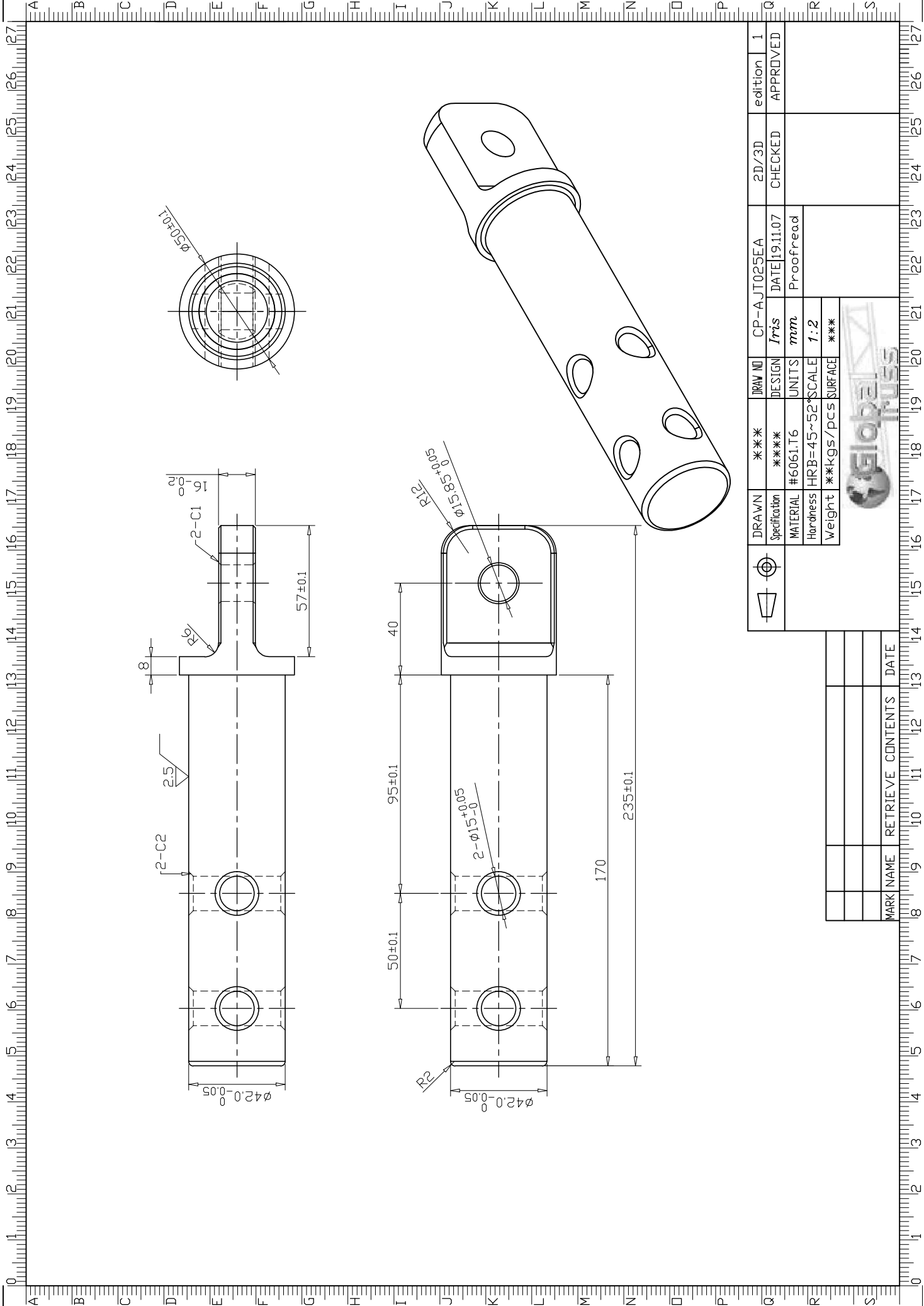

DRAWN Specification	***	DRAW NO	CP-AJT025EA	2D/3D	edition	1
	***	DESIGN	DATE 19.11.07	CHECKED	APPROVED	
MATERIAL	#6061.T6	UNITS	mm	Proofread		
Hardness	HRB=45~52	SCALE	1:2			
Weight	**kg/pcs	SURFACE	***			

MARK NAME	RETRIEVE CONTENTS	DATE



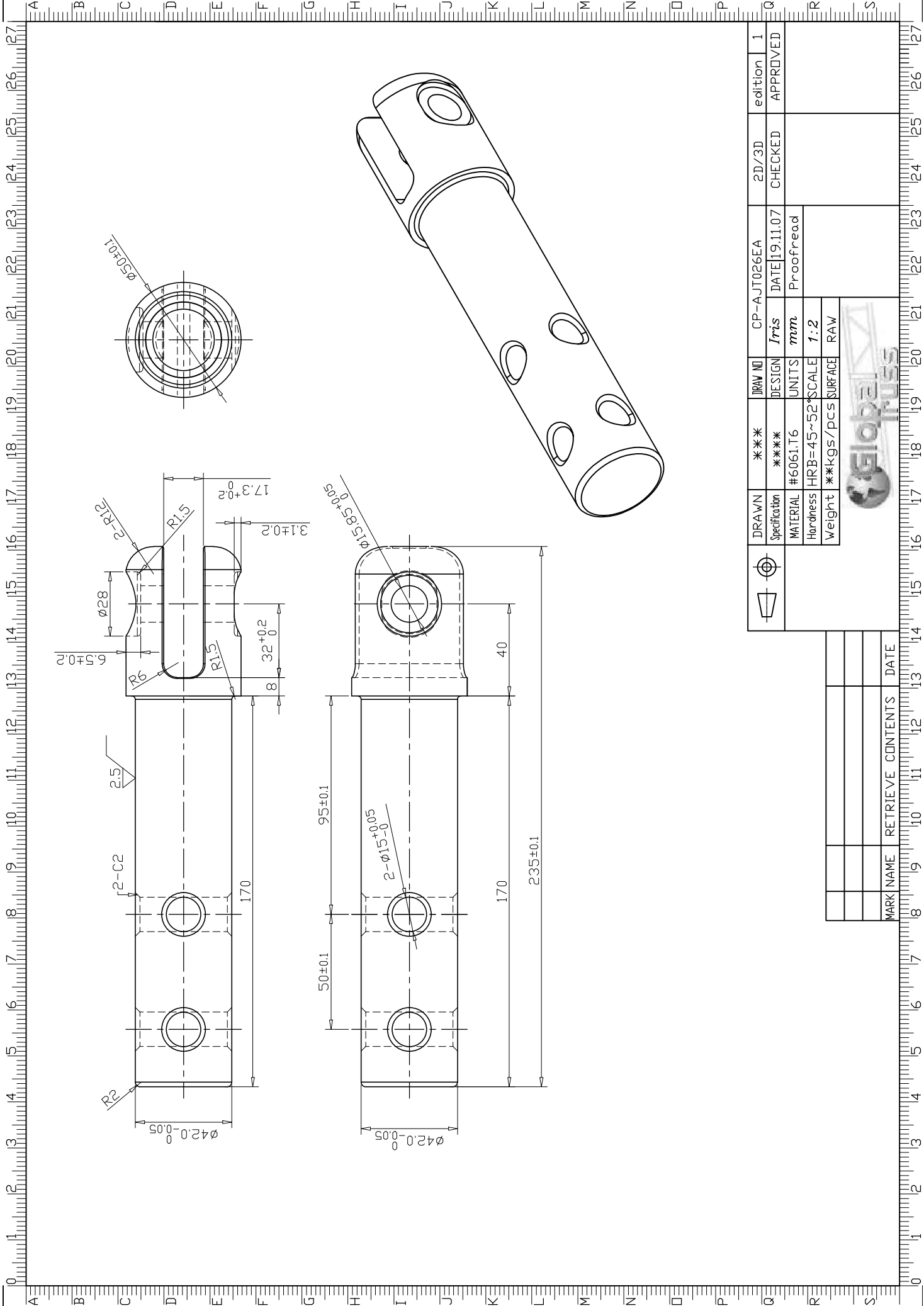

DRAWN	***	JRAW NO	CP-AJT026EA	2D/3D	edition	1
	Specification	DESIGN	DATE	CHECKED	APPROVED	
MATERIAL	#6061.T6	UNITS	mm	PROOFREAD		
Hardness	HRB=45~52	SCALE	1:2			
Weight	**kg/pcs	SURFACE	RAW			

MARK	NAME	RETRIEVE	CONTENTS	DATE

